

Fitting Instructions #2146IS

BMW E36 / E46 / Z4

Rear Trailing Arm Front Bushing

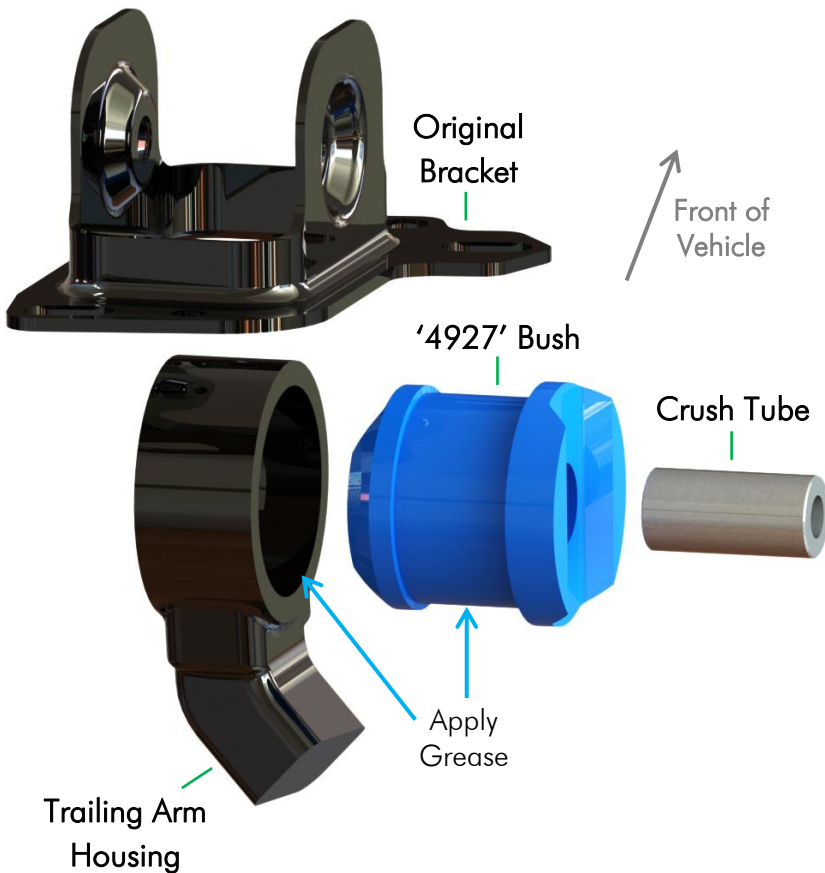
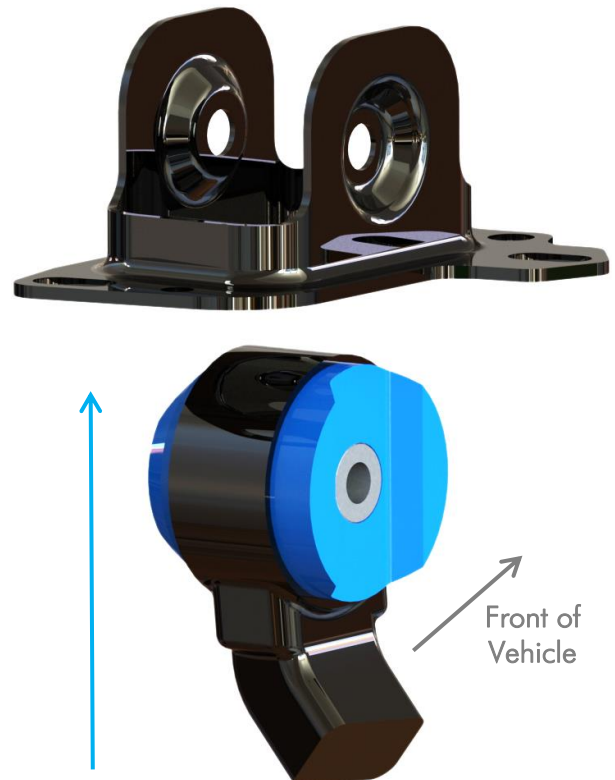

Figure 01 – '4927' Bush Installation

- Clean the housing and the brackets;
- Using the grease supplied, lubricate the housing and outside diameter of the new bushes and push them in, Figure 01 and Figure 02;
- Generously lubricate the outside of the steel tubes and inside of the bushes, then push the steel crush tubes into the bushes, Figure 01;
- Slide the control arm into the bracket, as show in Figure 02;
- Refit the trailing arms to the vehicle and tighten all bolts to manufacture's torque settings;
- Carry out wheel alignment.

Note: Polyurethane bushings must be fitted to both sides of the vehicle.

- Wheel-align the vehicle before the job is started and note settings;
- Jack the vehicle up and support on jack stands/hoist;
- Remove the rear trailing arms;
- Remove original shell parts from the housing with the use of a hydraulic press and suitable pressing tools;



Once the bush and crush tube is installed into the arm housing, slide the arm into the original bracket.

Figure 02 – '4927' Bush Installation