

Fitting Instructions #4346IS

Toyota Hilux / Prado

Front Lower Control Arm Rear Bushing

This instruction sheet is for SPF4346K (Standard) and SPF4347K (Offset) kits.

- Wheel align the vehicle before the job has started and check the camber/caster readings;
- Jack vehicle up on hoist/stands;
- Remove front lower control arms;
- Use a 20mm drill bit, drill through the washers to remove them from the crush tube;
- If using an oxy-acetylene torch you must be in a well ventilated area and use the appropriate safety equipment;
- Use the oxy-acetylene torch to heat the inner crush tubes until the bonding on the rubber has let go – push the crush tube out. Apply heat to the outside diameter of control arm until the rubber bonding lets go of the shell then push the remaining rubber out;
- Using a hacksaw or similar cut through the remaining shell then use a chisel to remove the shell from the control arm. Clean out the holes in the control arm and paint the eyes if they need to be;
- Using a hydraulic press and appropriate pressing tools press the new bush in making sure to fit the offset to the settings you require (0.6 degree camber change with maximum offset);
- The bushes fit in the same way as the original bushes, see diagrams in the next page;

Note: use a plate disc and press on the end of the urethane part of the bush as per photos and sketches over page.

- Use the grease supplied to lubricate the inside of the new bush, outside of the crush tube and the non-knurled face of the washers;
- Push the crush tube in and then line up the washers with the knurled faces pointing out on both sides and use a vice, etc., to press the washers onto the step of the crush tube;
- Refit the control arms and carry out a front wheel alignment;
- Recheck all bolts after 1000km or 1 month;
- Manufacture's torque setting must be used on all bolts.

Rear Bush
SPF4346K – Standard
SPF4347K – Offset



Fitting Instructions #4346IS

View from Rear of RHS

Standard

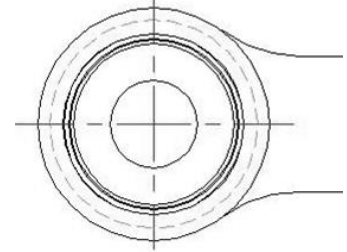

Negative Camber Increased for Raised Vehicles

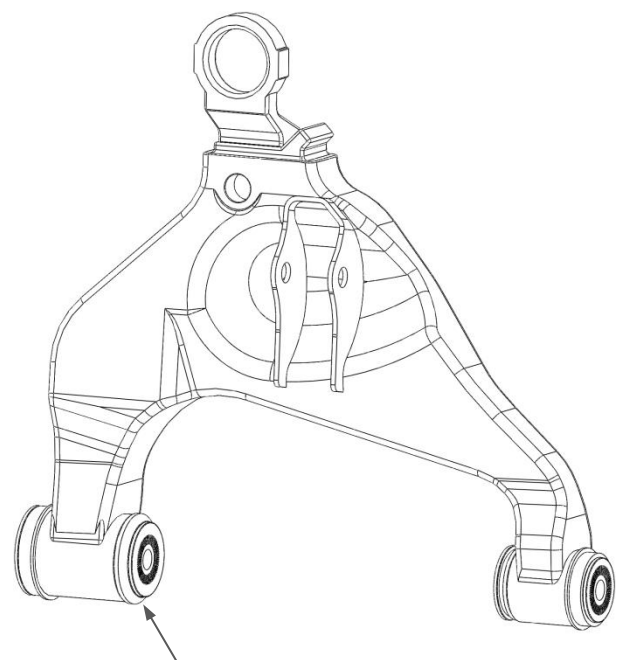
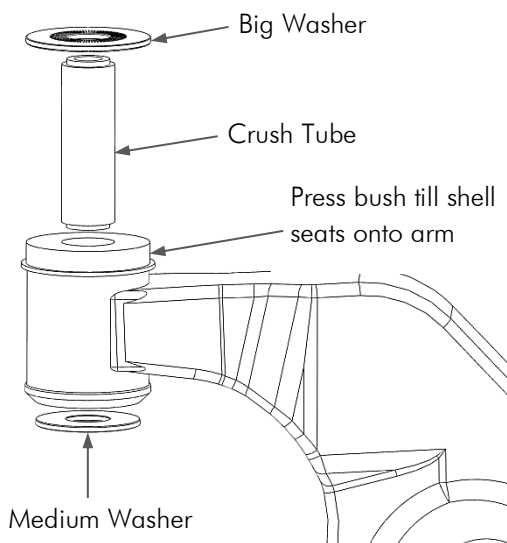
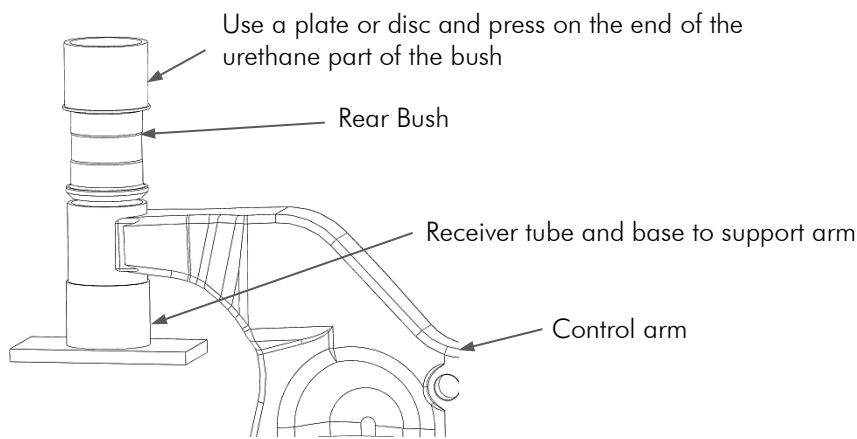
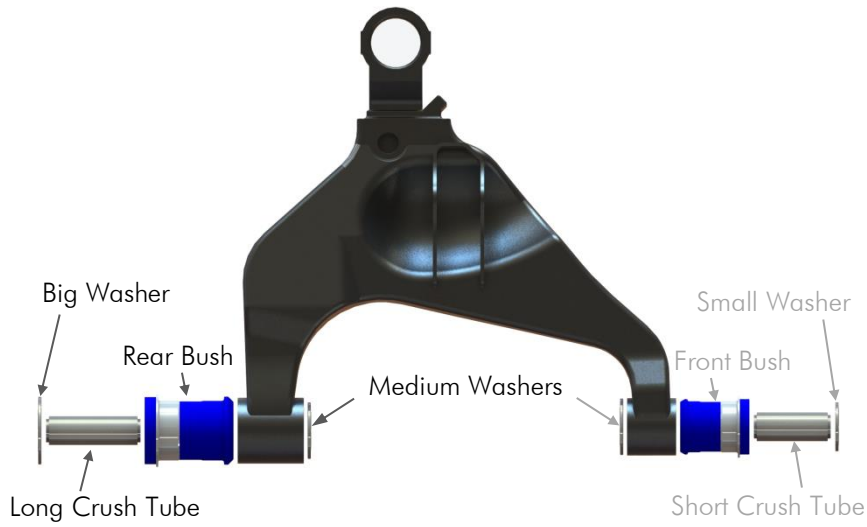
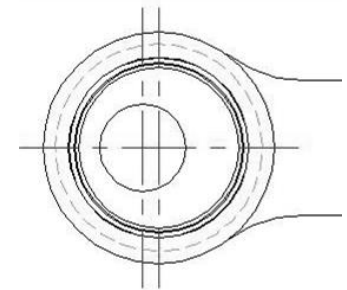

Rear bush completely installed.