

Fitting Instructions #TRC480IS

Toyota Prado 150 Series/Toyota FJ Cruiser 2011 - Adjustable Camber/Caster Upper Control Arms



1. Before beginning any alignment work, always check for loose or worn parts, proper tyre pressures, and odd tyre wear patterns. Replace any loose or worn parts before setting alignment;
2. Raise vehicle by the chassis and support with jack stands. Remove front tyre and wheel assemblies;
3. Loosen the nut on the upper arm-to-frame mounting bolt and remove bolt holding ABS wiring from upper arm;
4. Remove split pin and nut holding OEM ball joint to spindle. Break the taper between the ball joint stud and spindle and remove the ball joint from the spindle. Support the spindle so no strain is applied to ABS wiring or brake lines;
5. Remove the nut and washer from the long arm-to-frame mounting bolt and remove the bolt and arm.

Note: To provide clearance, additional components in the engine compartment may need to be removed;

6. Using supplied grease only, lightly coat the ends of the bushing;
7. Install the control arm to the vehicle;

Note washer arrangement in the illustration: reuse the OE washers in the original positions and add the supplied washers to the inside, see Figure 01. Note the OEs washer are cupped and should be installed as per Figure 01. Torque bolt-nut to 115 Nm. **Important:** Unlike OEM rubber bushings, SuperPro bushings pivot freely and so can be torqued without applying vehicle weight;

8. Install the star plate over the hex on the ball joint per the chart below to achieve the desired caster change relative to the stock arm. (For most vehicles with 2" of lift, it is recommended initially to set the ball-joint in the position "A" (Figure 02) for +4.0° caster change and make necessary adjustments using different positions on each side, if needed, to achieve desired cross-caster setting.) Insert the ball joint up through the bottom of the arm, indexing the star plate in the machined slot, and then install the top washer and nut. Position in full negative camber position of the slot and tighten nut for initial alignment readings;
9. Insert the ball joint stud into the spindle, install the supplied castle nut and torque to 110Nm. Tighten further until the supplied split pin can be installed;
10. Re-attach the ABS wiring bracket to the arm using factory bolt;
11. Re-install the tyre and wheel assembly. Lower the vehicle and take alignment readings. Adjust camber by loosening the top nut and sliding the ball joint in the control arm slot. Adjust caster by loosening the top nut and repositioning the star plate to rotate the ball joint relative to the arm. (It will be necessary to raise the vehicle to make these adjustments);
12. When final caster/camber settings are achieved, torque the top ball joint nut to 143 Nm. adjust toe, road test the vehicle.

Camber and caster can be set with the upper control arm, as well as the OEM lower control arm camber pins. It is recommended to set the ball-joint in the position "A", then make necessary adjustments to achieve the desired camber and caster using the upper control arm and fine tune with the lower control arm.

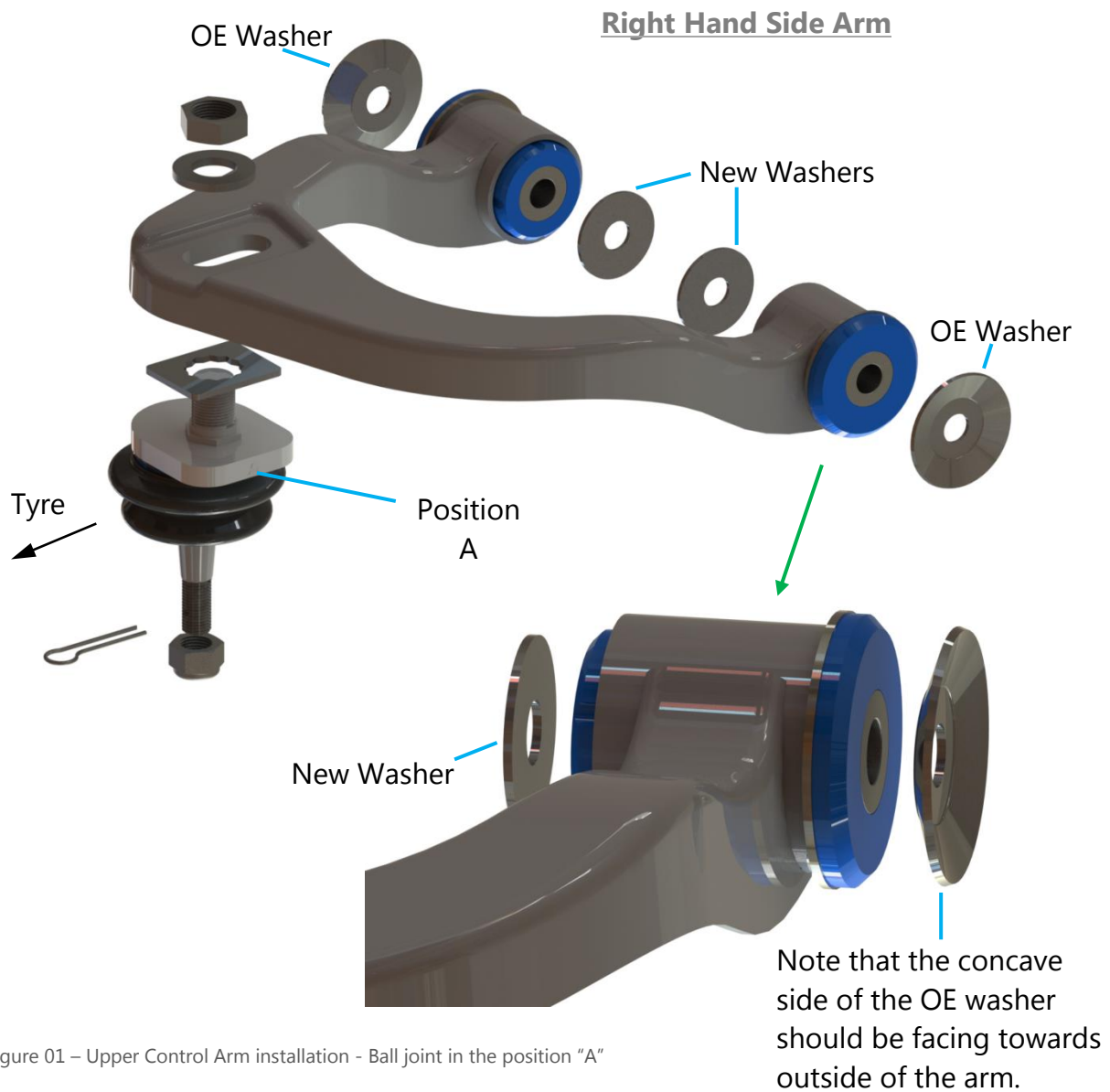
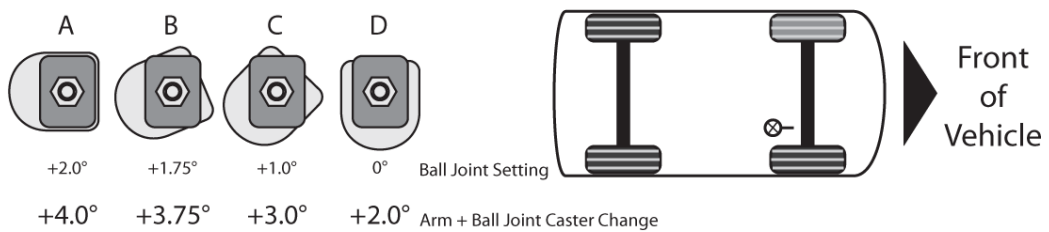

Figure 01 – Upper Control Arm installation - Ball joint in the position "A"

LEFT FRONT CASTER CHANGE



RIGHT FRONT CASTER CHANGE

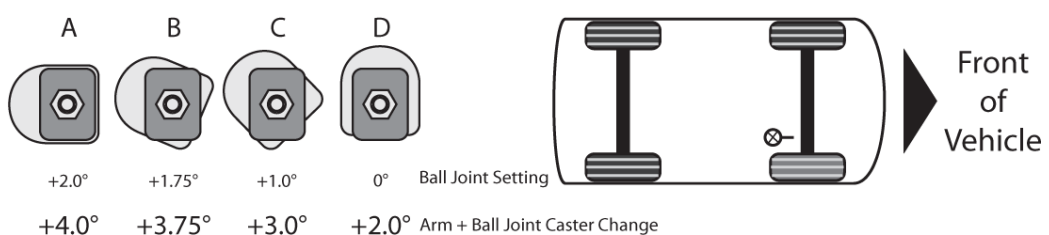

Figure 02 – Caster Settings